

Gelenkkopf GSA V Z S20

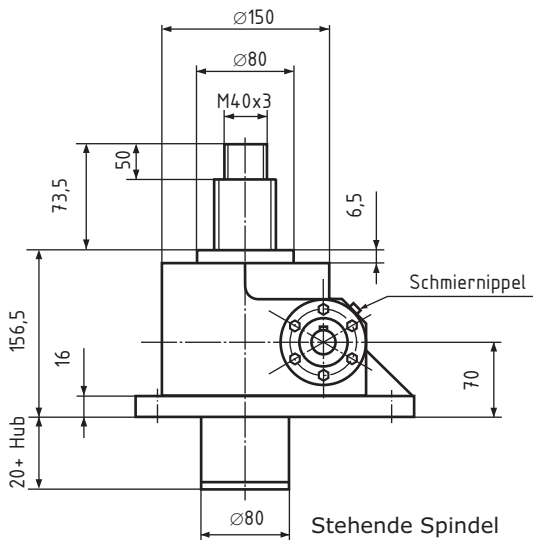

Stehende Spindel

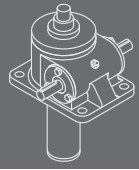
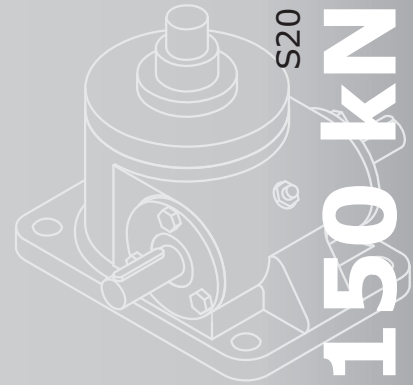
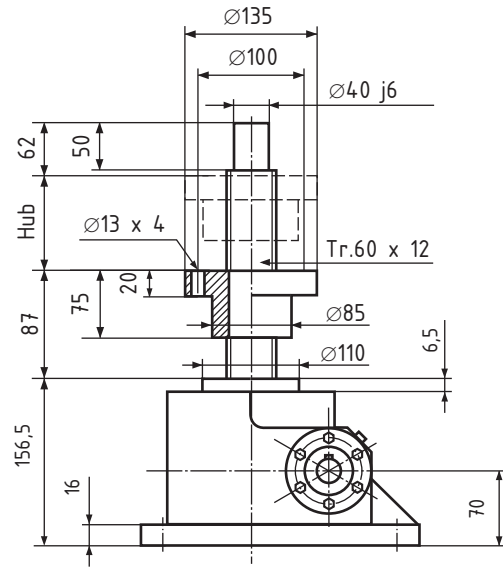

Rotierende Spindel

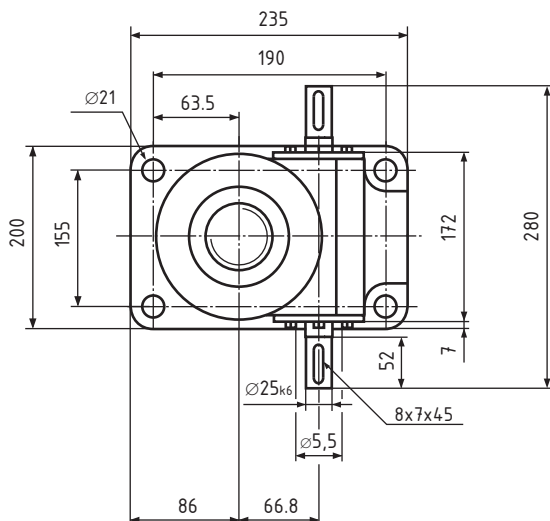

GS VI S20

Trapez-Gewindespindel Tr. 60 x 12

Hubkraft 150kN

Übersetzung

Standard 24:1

Schnell 7,66:1

Hub pro Umdrehung

Standard 0,50 mm

Schnell 1,565 mm

Max. Eintriebsdrehzahl 1500 1/min

Wirkungsgrad ca. 27 %

Gehäusewerkstoff Stahl

Gewicht ca. 27 kg

N=Standard

R=Rotierende Spindel

Bestellbeispiel:

GS, Baugröße **VI**, Variante **R**, **S20**, Hublänge **1220**

Bestellnummer: **GS VI R S20 1220**