

Spindelhubgetriebe GS IV Standard

50 kN
Standard

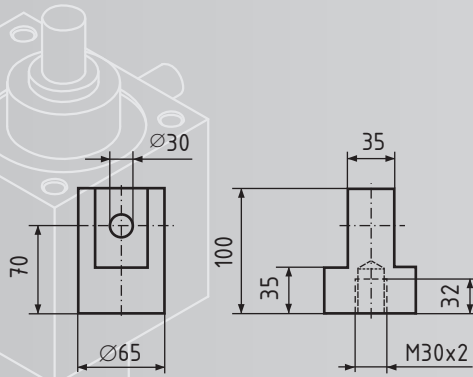

Gelenkkopf GSA IV Z

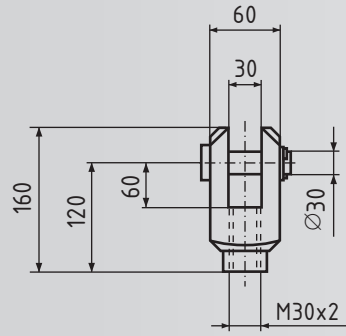

Gabelkopf GSA IV G

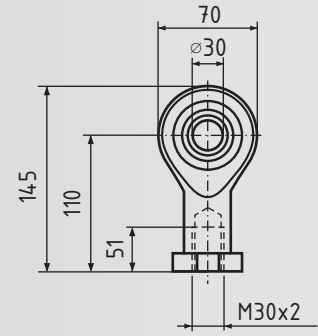

Kugelgelenkkopf GSA IV K

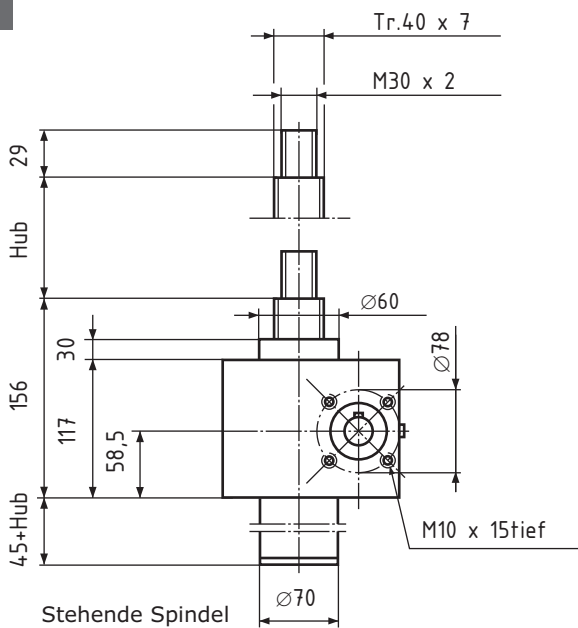
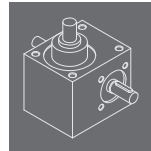

Stehende Spindel

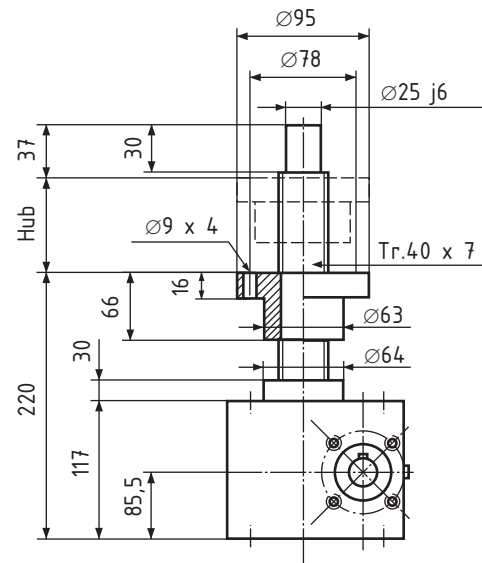

Rotierende Spindel

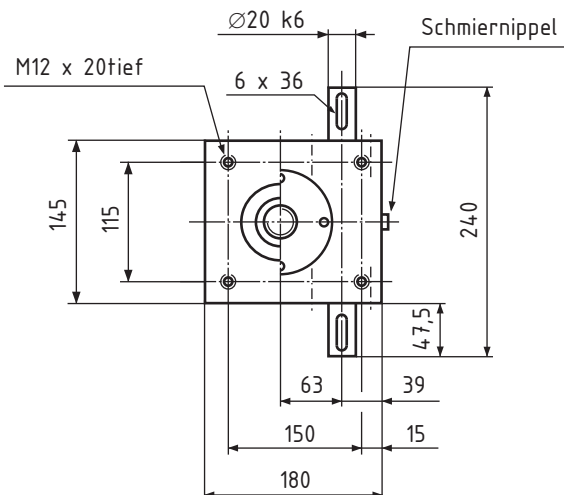

GS IV

Trapez-Gewindespindel Tr. 40 x 7

Hubkraft 50kN

Übersetzung

Standard 28:1

Schnell 7:1

Hub pro Umdrehung

Standard 0,25 mm

Schnell 1,00 mm

Max. Eintriebsdrehzahl 1500 1/min

Wirkungsgrad ca. 27 %

Gehäusewerkstoff Stahl

Gewicht ca. 24 kg

N=Standard

R=Rotierende Spindel

Bestellbeispiel:

GS, Baugröße **IV**, Variante **R**, Hublänge **2250**

Bestellnummer: **GS IV R 2250**