

Spindelhubgetriebe GS 0 Standard

2,5 kN
Standard

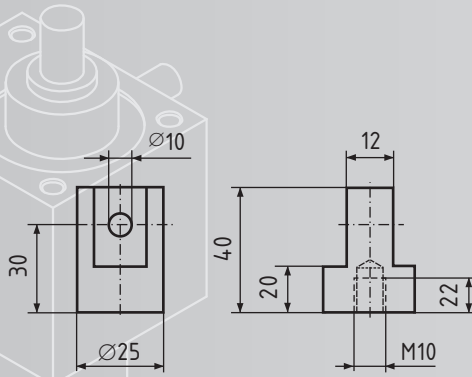

Gelenkkopf GSA 0 Z

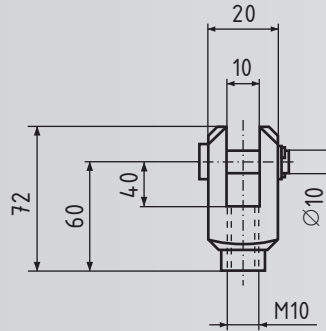

Gabelkopf GSA 0 G

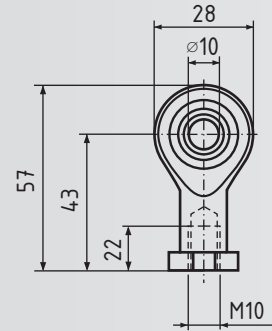

Kugelgelenkkopf GSA 0 K

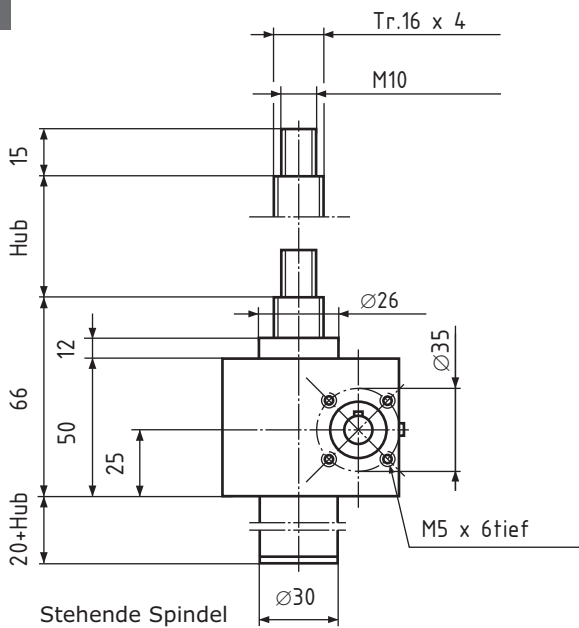
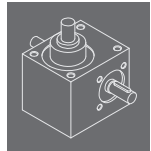

Stehende Spindel

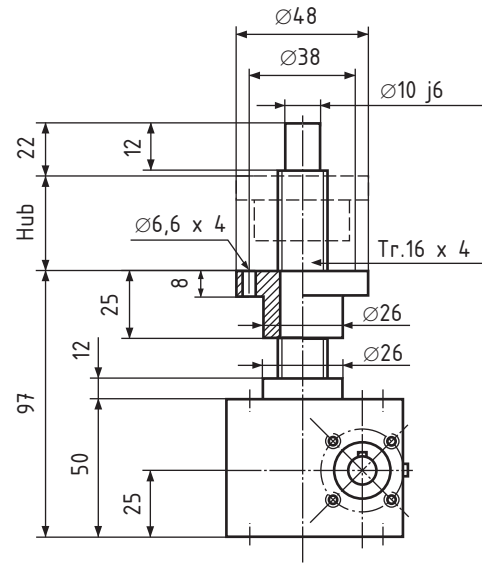

Rotierende Spindel

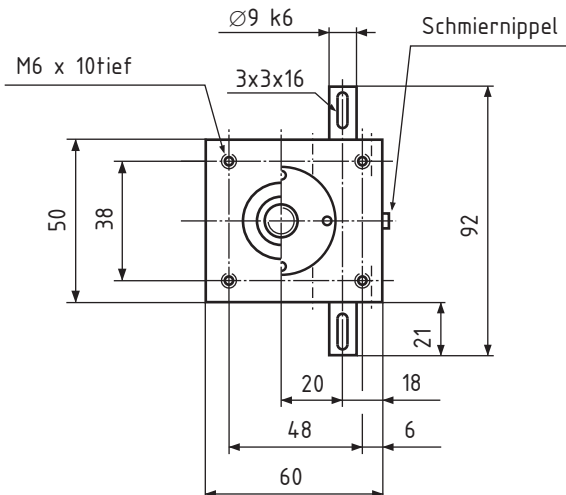

GS 0

Trapez-Gewindespindel Tr. 16 x 4

Hubkraft 2,5kN

Übersetzung

Standard 16:1

Schnell 4:1

Hub pro Umdrehung

Standard 0,25 mm

Schnell 1,00 mm

Max. Eintriebsdrehzahl 1500 1/min

Wirkungsgrad ca. 30 %

Gehäusewerkstoff Alu

Gewicht ca. 0,6 kg

N=Standard

R=Rotierende Spindel

Bestellbeispiel:

GS, Baugröße **0**, Variante **N**, Hublänge **250**

Bestellnummer: **GS 0 N 250**